



H6544A-PA265 SYSTEM DATASHEET



SYSTEM PERFORMANCE	METRIC	IMPERIAL
Sine Force Peak kN (lbf)	63.7	14,320
Random Force rms kN (lbf)	63.7	14,320
Shock Force (6ms) kN (lbf)	127.4/191.1**	28,641/42,961**
Useful Frequency Range Hz	5-2500	5-2500
Continuous Displacement mm (in)	51/76*	2.0/3.0*
Shock Displacement mm (in)	51/76*	2.0/3.0*
Max Velocity m/s (in/s)	2/2.5**	78.7/98.4**
Max Acceleration Sine Peak m/s ² (g)	980	100

Water-cooled system ideally suited to test medium to large-sized electronic parts, connectors, hand-held units and large mechanical assemblies.

- Continuous displacement 51 mm (2.0 in) / 76 mm (3.0)*
- Useable frequency range 5 - 2500 Hz
- Max static payload 1000 kg (2205 lb)
- Air-cooled amplifier efficiency > 90%
- Rugged isolated trunnion

* With LSO and TSO option

** Only available with TSO option

H6544A SHAKER	METRIC	IMPERIAL
Armature Diameter mm (in)	445	17.5
Armature Material	Al	Al
Effective Armature Mass kg (lb)	60	133
Armature Insert Pattern PCD mm (in)	8-200/8-400	8-8/8-16
Armature Insert Threads	M16	1/2 - 13 UNC
First Resonant Frequency (bare table) ±5% Hz	2100	2100
Max Static Payload kg (lb)	1000	2205
Natural Frequency Thrust Axis Hz	< 5	< 5
Shaker Weight Uncrated kg (lb)	5,500	12,125

SLIP TABLES

Mono-base slip tables in a wide-range of sizes and configurations for maximum over-turning moment and cross-axial restraint

PA265 POWER AMPLIFIER	METRIC	IMPERIAL
Number of Sub-modules Supplied	14	14
Rated Power Output kVA	70	70
Rated Output Voltage V rms	100	100
Rated Output Current A rms	680	680
Number of Cabinets	2	2
System Required Power kVA	85	85
Amplifier Weight Uncrated kg (lb)	1200	2646
Dimensions Uncrated (W x D x H) mm (in)	1160 x 850 x 1800	45.7 x 33.5 x 70.9

OPTIONS & ACCESSORIES

Sentek Dynamics offers a wide selection of options and accessories for unique applications and complete turn-key systems.

- Custom armature and slip table insert patterns and threads available
- Air-isolation feet, pads and mounts to eliminate need for seismic floor
- Thermal barrier for use with environmental test chambers
- Remote control panel for remote operation

CU-3 WATER COOLING UNIT	METRIC	IMPERIAL
Power Requirement (3-phase) kVA	4	4
Min Facility Cooling Water (Flow L/Min) (gpm)	220	58.1
Max Facility Cooling Water Temp °C (°F)	25	77
Dimensions (W x D x H) mm (in)	850 x 850 x 1900	33.5 x 33.5 x 74.8
Cooling Unit Weight Uncrated kg (lb)	550	1213



SHAKER MODEL H6544A

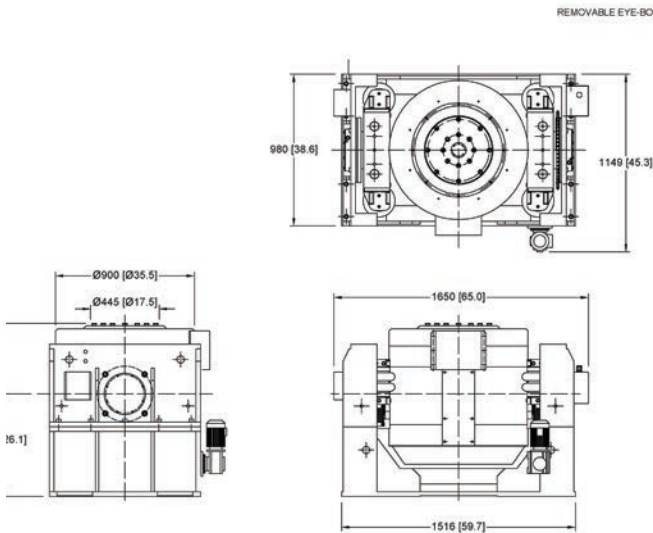

POWER AMPLIFIER MODEL PA265

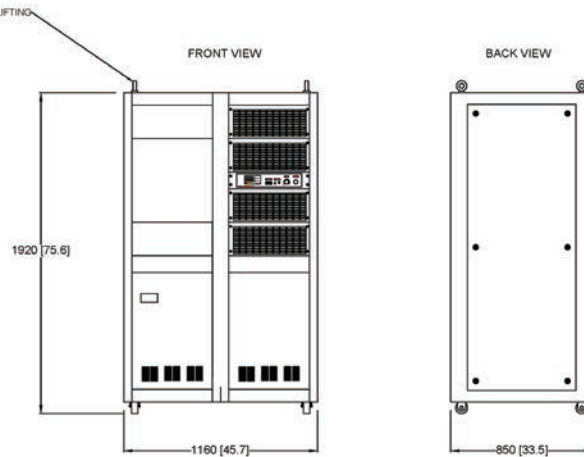

ARMATURE INSERT PATTERN

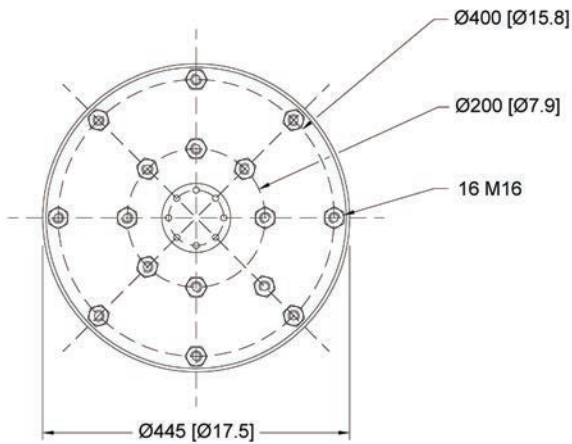

WATER COOLING UNIT CU-3

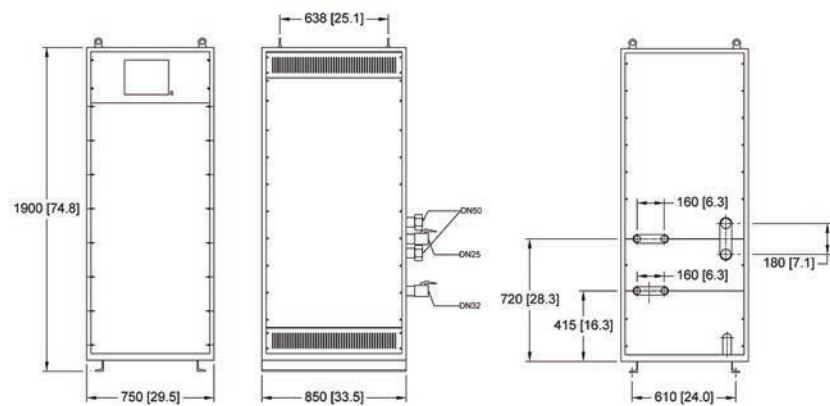

SENTEK DYNAMICS
 2370 OWEN STREET
 SANTA CLARA, CA 95054
 UNITED STATES OF AMERICA

PHONE: +1.408.200.3100 | FAX: +1.408.659.8229 | WWW.SENTEKDYNAMICS.COM | SALES@SENTEKDYNAMICS.COM

© 2017 Sentek Dynamics, All Rights Reserved. 09/2017

Notice: This document is for informational purposes only and does not set forth any warranty, expressed or implied, concerning any equipment, equipment feature, or service offered or to be offered by Sentek Dynamics. Sentek Dynamics reserves the right to make changes to this document at any time, without notice, and assumes no responsibility for its use. This informational document describes features that may not be currently available. Contact a Sentek Dynamics sales representative for information on features and product availability.