

General description

The InnaLabs® **AI-Q-710** tactical grade accelerometer is an ideal, ITAR-Free choice for aerospace, defence, industrial, transport, and civil engineering applications.

The AI-Q-710 quartz-based servo accelerometer offers a dynamic range of ± 30 g with a one-year bias composite repeatability better than 1200 μ g in a compact and ruggedised casing that provides a high shock and vibration resistance, matching the highest industry standards at a very economical price.

The AI-Q-710 features an internal temperature sensor that allows the user to carry out temperature calibration and compensation, enhancing the bias, scale factor and axis misalignment performance over temperature.

The AI-Q-710 is the optimum choice for a wide range of military and civilian applications such as: platform leveling, low-end tactical grade IMUs, INS for land military vehicles, control sensors for high speed trains, structural health monitoring and seismic sensors.



State-of-the-art manufacturing processes enable InnaLabs® to offer AI-Q-710 accelerometers at competitive prices.

Accelerometer dimensions (mm)

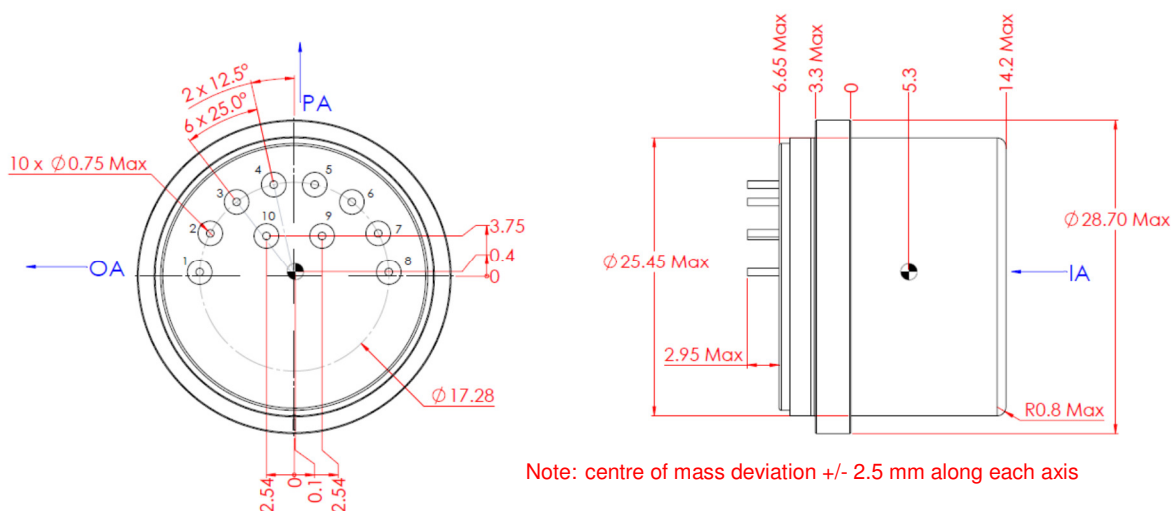

Note: centre of mass deviation +/- 2.5 mm along each axis

Features

- Tactical grade performance (<1200 μ g one year bias composite repeatability)
- High input range (up to ± 30 g)
- Environmentally rugged
- Analogue current output
- Compact design
- High thermal stability
- Internal temperature sensor for thermal compensation
- Dual built-in self test
- ITAR-Free

Applications

- Tactical grade Inertial Navigation Systems (INS)
- Inertial Measurement Units (IMUs)
- Flight control systems
- Unmanned systems and helicopters
- Platform leveling
- Structural health and maintenance
- Land and marine vehicles
- Inclinerometers for industrial and drilling
- Train and rail measurement systems
- Robotic systems control
- Seismic sensing

Specifications

Parameters	Units	Values
Input Range	g	±30
Bias	mg	<8
One-year Composite Repeatability	µg	<1200
Temperature Sensitivity	µg/°C	<70
Scale Factor	mA/g	1.23 to 1.43
One-year Composite Repeatability	ppm	<1200
Temperature Sensitivity	ppm/°C	<200
Axis Misalignment	µrad	<2000
Vibration Rectification	µg/g ² _{RMS}	<50 (50-200 Hz) <100 (200-750 Hz) <150 (750-2000 Hz)
Intrinsic Noise	µg _{RMS}	<7 (0-10 Hz) <70 (10-500 Hz) <1500 (500-10000 Hz)
Operating Temperature	°C	-55 to +96
Shock	g	250
Vibration Peak Sine	g, Hz	25g @ 20 to 2000 Hz
Resolution/Threshold	µg	<1
Bandwidth	Hz	>300
Temperature Model		Yes
Quiescent Current per Supply	mA	<16
Quiescent Power @±15V _{DC}	mW	<480
Electrical interface		Temp Sensor
		Voltage Self Test
		Current Self Test
		Power/Signal Ground
		-10V _{DC} Output
		+10V _{DC} Output
Input Voltage	V _{DC}	±13 to ±28
Weight	g	53 ± 2
Diameter below mounting surface	mm	Ø 25.45 Max
Height – bottom to mounting surface	mm	14.2 Max
Case Material		300 Series Stainless Steel

How to order

AI-Q-710 is orderable under this part number from InnaLabs® and our worldwide network of Agents and Distributors.

Related Products

InnaLabs® offers a range of accelerometers based on the same design and production processes, including the AI-Q-1400 and AI-Q-2000 series.

Contact your local InnaLabs® Sales Agent for further details, or visit www.innalabs.com.

If you wish to be automatically updated on future releases of this product datasheet, please contact your local InnaLabs® Sales Agent.

Disclaimer: The document is subject to change without notice. InnaLabs® reserves the right to make changes to any product or technology herein. InnaLabs® does not assume any liability arising out of the application or use of the product.