

General description

The InnaLabs® **AI-Q-1410** navigation grade accelerometer offers high performance at a moderate price. The AI-Q-1410 is an ideal ITAR-Free solution for a wide range of aerospace, defence and industrial applications.

The proven quartz flexure technology inside InnaLabs® accelerometers provides a very high input range and very good long-term repeatability, which make the AI-Q-1410 an optimal solution for medium-high performance AHRS, strap-down INS and many other defence and high-end industrial applications.

The AI-Q-1410 features an internal temperature sensor that allows the user to carry out temperature calibration and compensation, enhancing the bias, scale factor and axis misalignment performance over temperature.



State-of-the-art manufacturing processes enable InnaLabs® to offer AI-Q-1410 accelerometers at competitive prices.

Accelerometer Dimensions (mm)

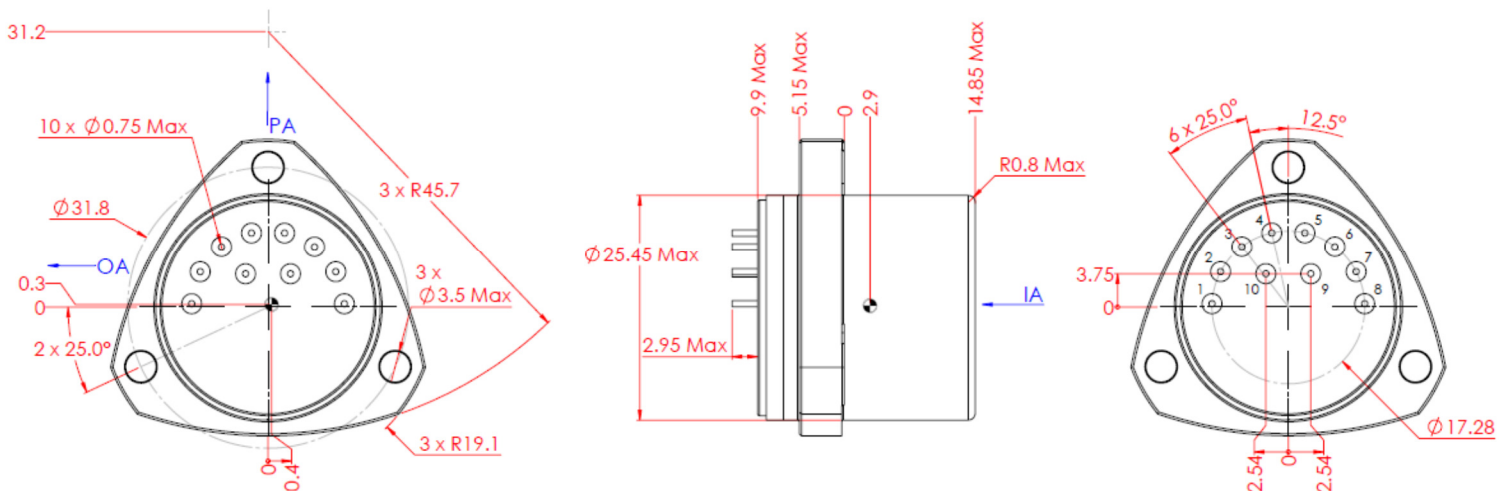

Features

- Navigation grade performance (1000 µg one year bias composite repeatability)
- High input range (up to ±60g measurement range)
- Analogue current output
- Compact, rugged design
- High stability under temperature changes
- High reliability
- Internal temperature sensor for thermal compensation
- Dual built-in self test
- ITAR-Free

Applications

- Inertial Navigation Systems (INS)
- Inertial Measurement Units (IMU)
- Attitude and Heading Reference Systems (AHRS)
- Commercial and military aircraft
- Unmanned systems and helicopters
- Land and marine vehicles
- Orientation systems for oil drilling industry
- Train and rail measurement systems
- Robotic systems control
- Inclinerometers

Specifications

Parameters	Units	Values
Input Range	g	±60
Bias	mg	<5
One-year Composite Repeatability	µg	<1000
Temperature Sensitivity	µg/°C	<90
Scale Factor	mA/g	1.2 to 1.46
One-year Composite Repeatability	ppm	<1000
Temperature Sensitivity	ppm/°C	<180
Axis Misalignment	µrad	<7000
One-year Composite Repeatability	µrad	<200
Vibration Rectification	µg/g ² _{RMS}	<60 (50-500 Hz) <150 (500-2000 Hz)
Intrinsic Noise	µg _{RMS}	<7 (0-10 Hz) <70 (10-500 Hz) <1500 (500-10000 Hz)
Operating Temperature	°C	-55 to +95
Shock	g	250
Vibration Peak Sine	g, Hz	20g @ 20 to 2000 Hz
Resolution/Threshold	µg	<1
Bandwidth	Hz	>300
Temperature Model		Yes
Quiescent Current per Supply	mA	<16
Quiescent Power @ ±15V _{DC}	mW	<480
Electrical interface		Temp Sensor
		Voltage Self Test
		Current Self Test
		Power/Signal Ground
		-10 V _{DC} Output
		+10 V _{DC} Output
Input Voltage	V _{DC}	±13 to ±28
Weight	g	64 ±4
Diameter below mounting surface	mm	Ø 25.45 Max
Height – bottom to mounting surface	mm	14.85 Max
Case Material		300 Series Stainless Steel

How to order

AI-Q-1410 is orderable under this part number from InnaLabs® and our worldwide network of Agents and Distributors.

Related Products

InnaLabs® offers a range of accelerometers based on the same design and production processes, including the AI-Q-700 and AI-Q-2000 series.

Contact your local InnaLabs® Sales Agent for further details, or visit www.innalabs.com.

If you wish to be automatically updated on future releases of this product datasheet, please contact your local InnaLabs® Sales Agent.

Disclaimer: The document is subject to change without notice. InnaLabs® reserves the right to make changes to any product or technology herein. InnaLabs® does not assume any liability arising out of the application or use of the product.