

HS-150T Premium Accelerometer

AC acceleration and temperature output via PUR Cable

Key Features

- Waterproof
- Resistant to oil
- Temperature output

Industries

Building services, Pulp and Paper, Mining, Metals, Utilities, Automotive, Water, Pharmaceutical

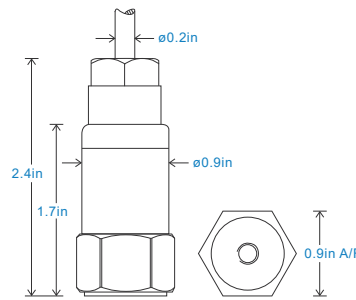

Connection Details

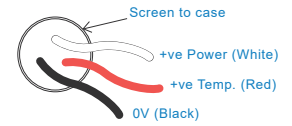

Technical Performance

Mounted Base Resonance	see 'How To Order' table (nominal)
Sensitivity	see: 'How To Order' table $\pm 10\%$ Nominal 80Hz at 72°F
Frequency Response	90cpm (1.5Hz) to 600kcpm (10kHz) $\pm 5\%$ 30cpm (0.5Hz) to 720kcpm (12kHz) $\pm 10\%$ 12cpm (0.2Hz) to 900kcpm (15kHz) $\pm 3\text{dB}$
Isolation	Base isolated
Range	see: 'How To Order' table
Temperature Output	10 mV/°C standard 212°F - Option 266°F
Transverse Sensitivity	Less than 5%

Mechanical

Case Material	Stainless Steel
Sensing Element/Construction	PZT/Shear
Mounting Torque	5.9ft. lbs
Weight	3.7 oz. (nominal) body only
Maximum Cable Length	3,280 ft.
Standard Cable Length	16 ft.
Shielded Cable	PUR - length to be specified with order
Mounting Threads	see: 'How To Order' table
Submersible Depth	328 ft. max (10 bar)

Electrical

Excitation Voltage:	18-30Volts DC
Electrical Noise	0.1mg max
Current Range	0.5mA to 8mA
Bias Voltage	10 - 12 Volts DC
Settling Time	1 second
Output Impedance	200 Ohms max.
Case Isolation	$>10^8$ Ohms at 500 Volts

Environmental

Operating Temperature Range	-22 to 194°F
Sealing	IP68
Maximum Shock	5000 g
EMC	EN61326-1:2013

Typical Frequency Response (at 100mV/g)

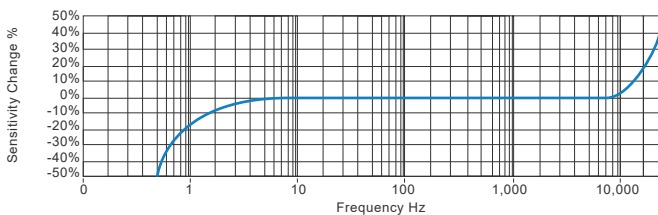

Applications

Fans, Motors, Pumps, Compressors, Centrifuges, Conveyors, Air Handlers, Gearboxes, Rolls, Dryers, Presses, Cooling, VAC, Spindles, Machine Tooling, Process Equipment

Vibration sensor should be firmly fixed to a flat surface (spot face surface may be needed to be produced and cable anchored to sensor body.)

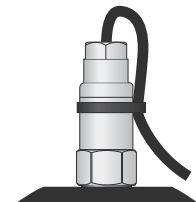

How To Order

Product Prefix HS - Hansford Sensors	Product Series 150 - Premium Industrial Vibration Sensor	Cable Length (if integral cable) UXX - length specified in feet													
H	S	1	5	0	T	X	X	X	X	X	X	X	X	X	X
Extra Options (if required) F - Filtered L - 316L Stainless Steel S - 90° Side Exit T - Temperature Output Y - 5% tolerance on sensitivity	Sensitivity 010 - 10mV/g $\pm 800\text{g}$ 030 - 30mV/g $\pm 250\text{g}$ 050 - 50mV/g $\pm 160\text{g}$ 100 - 100mV/g $\pm 80\text{g}$ 250 - 250mV/g $\pm 32\text{g}$ 500 - 500mV/g $\pm 16\text{g}$	Range $\pm 800\text{g}$ $\pm 250\text{g}$ $\pm 160\text{g}$ $\pm 80\text{g}$ $\pm 32\text{g}$ $\pm 16\text{g}$	Resonant Frequency 2,040kcpm (34kHz) 1,980kcpm (33kHz) 1,920kcpm (32kHz) 1,800kcpm (30kHz) 1,680kcpm (28kHz) 1,560kcpm (26kHz)	Cable/Connector 01 - PUR 03 - Braided 07 - Silicon 15 - Flame Retardant 52 - 3 Pin MS 54 - M12	Mounting Threads 01 - ¼-28" UNF Female 02 - ¼-28" UNF Male 05 - Quick Fit Female 06 - M6 x 1mm Male 08 - M8 x 1.25mm Male 10 - M10 x 1.5mm Male										



www.hansfordsensors.com
sales@hansfordsensors.com

We reserve the right to alter the specification of this product without prior notice

TS280U.6

