

HS-150S Premium Accelerometer

AC acceleration output via 4 Core Polyolefin HFFR with Protective Conduit

Key Features

- High Temperature
- Protective Conduit
- Premium design

Industries

Building services, Pulp and Paper, Mining, Metals, Utilities, Automotive, Water, Pharmaceutical

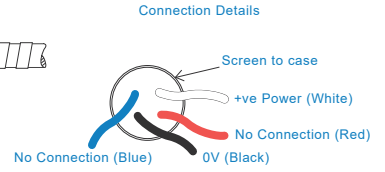
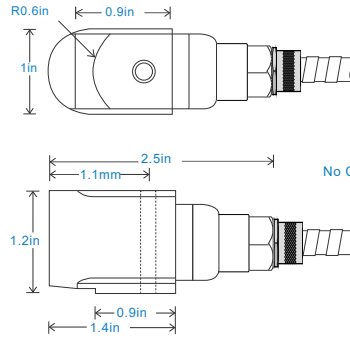
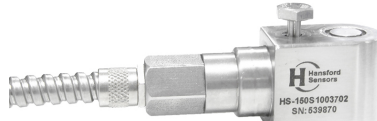

Technical Performance

Mounted Base Resonance	see 'How To Order' table (nominal)
Sensitivity	see: 'How To Order' table $\pm 10\%$ Nominal 80Hz at 72°F
Frequency Response	120cpm (2Hz) to 600kcpm (10kHz) $\pm 5\%$ 90cpm (1.5Hz) to 720kcpm (12kHz) $\pm 10\%$ 48cpm (0.8Hz) to 900kcpm (15kHz) $\pm 3dB$
Isolation	Base isolated
Range	see: 'How To Order' table
Transverse Sensitivity	Less than 5%

Mechanical

Case Material	Stainless Steel
Sensing Element/Construction	PZT/Shear
Mounting Torque	5.9ft. lbs
Mounting Bolt provided	see: 'How To Order' table x 1.4in long
Weight	7.2 oz. (nominal) body only
Maximum Cable Length	3,280 ft.
Standard Cable Length	16 ft.
Screened Cable	Polyolefin HFFR - length to be specified with order
Mounting Threads	see: 'How To Order' table
Submersible Depth	328 ft. max (10 bar)

Electrical

Excitation Voltage:	18-30Volts DC
Electrical Noise	0.1mg max
Current Range	0.5mA to 8mA
Bias Voltage	10 - 12 Volts DC
Settling Time	2 seconds
Output Impedance	200 Ohms max.
Case Isolation	$>10^8$ Ohms at 500 Volts

Environmental

Operating Temperature Range	-67 to 266°F
Sealing	IP68
Maximum Shock	5000g
EMC	EN61326-1:2013

Typical Frequency Response (at 100mV/g)

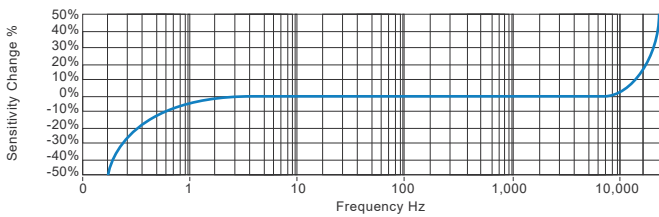

Applications

Fans, Motors, Pumps, Compressors, Centrifuges, Conveyors, Air Handlers, Gearboxes, Rolls, Dryers, Presses, Cooling, VAC, Spindles, Machine Tooling, Process Equipment

Vibration sensor should be firmly fixed to a flat surface (spot face surface may be needed to be produced and cable anchored to sensor body.)

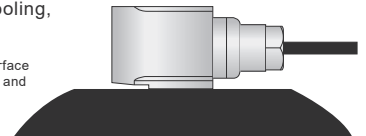

How To Order

Product Prefix HS - Hansford Sensors	Product Series 150 - Premium Industrial Vibration Sensor										
<p>H S 1 5 0 S X X X X X X</p>											
Extra Options (if required) F - Filtered L - 316L Stainless Steel RT - Temperature Output PT100 S - 90° Side Exit T - Temperature Output Y - 5% tolerance on sensitivity H - High Temperature	Sensitivity 010 - 10mV/g 030 - 30mV/g 050 - 50mV/g 100 - 100mV/g 250 - 250mV/g 500 - 500mV/g	Range $\pm 800g$ $\pm 250g$ $\pm 160g$ $\pm 80g$ $\pm 32g$ $\pm 16g$	Resonant Frequency 34kHz (2,040kcpm) 33kHz (1,980kcpm) 32kHz (1,920kcpm) 30kHz (1,800kcpm) 28kHz (1,680kcpm) 26kHz (1,560kcpm)	Cable/Connector 37C - 4 Core Polyolefin HFFR with Protective Conduit	Mounting Threads 02 - 1/4-28" UNF Male 06 - M6 x 1mm Male 08 - M8 x 1.25mm Male						



www.hansfordsensors.com
sales@hansfordsensors.com

We reserve the right to alter the specification of this product without prior notice
TS990U.1

