

PROPRIETARY AND CONFIDENTIAL

THE INFORMATION CONTAINED IN THIS DRAWING IS THE SOLE PROPERTY OF DYTRAN INSTRUMENTS INC. ANY REPRODUCTION IN PART OR AS A WHOLE WITHOUT THE WRITTEN PERMISSION OF DYTRAN INSTRUMENTS INC. IS PROHIBITED

1 CABLE LENGTH TOLERANCE

ENGLISH		METRIC	
≤1FT	+1/ -0 IN	≤0.3m	+25mm/-0mm
>1 FT - 5 FT	+2/ -0 IN	>0.3m-1.5m	+50mm/-0mm
> 5 FT - 10 FT	+4/ -0 IN	>1.5m-3m	+100mm/-0mm
>10 FT - 25FT	+6 / -0 IN	>3m-7.5m	+150mm/-0mm
>25 FT	+5% / -0%	>7.5m	+5%-0%

REVISIONS

REV.	ECN	DESCRIPTION	BY/DATE	CHK	APPR
B	15180	SEE ECN	DA, 06/27/19	Sp	hw

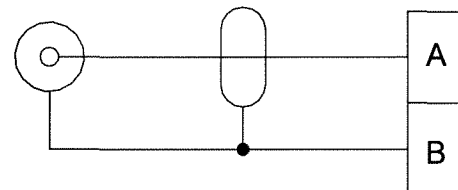
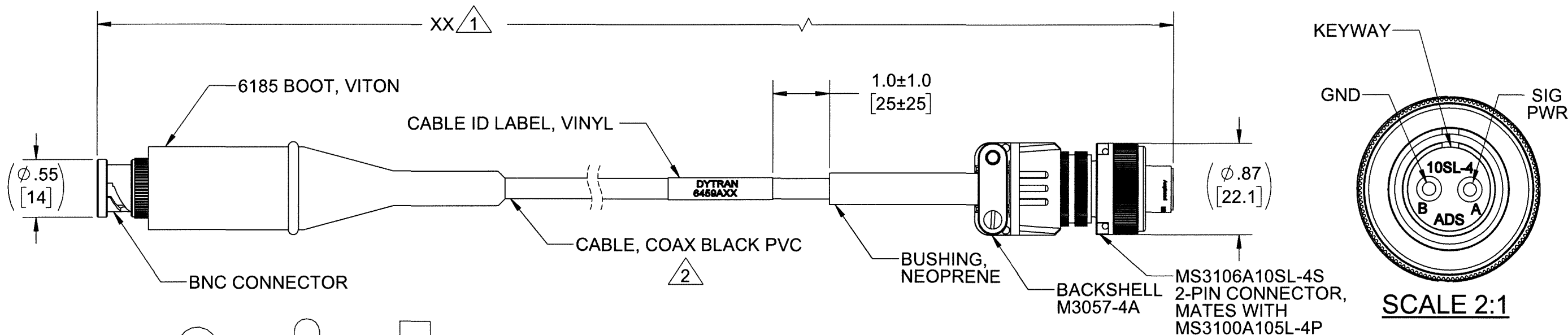

SCHEMATIC DIAGRAM

2 CABLE, COAXIAL, RG58C/U (MIL-DTL-17)

CENTER CONDUCTOR	20 AWG 19/33 TINNED COPPER CONDUCTOR
INSULATION	POLYETHYLENE ϕ .116 ±.004
SHIELD	36 AWG TINNED COPPER BRAIDED SHIELD 95% COVERAGE
JACKET	BLACK PVC, NON CONTAMINATING
DIAMETER	.195 ±.007
TEMPERATURE RATING	-40 ° C (-40 ° F) TO +85 ° C (185 ° F)

- 3. TEMPERATURE: -26 ° C TO +85 ° C (-14.8 ° F TO +185 ° F)
- 2 SEE CABLE SPECIFICATION TABLE.
- 1 PART NUMBER 6459AXX (XX DENOTES LENGTH IN FEET)

NOTES: UNLESS OTHERWISE SPECIFIED

UNLESS OTHERWISE SPECIFIED:
 INTERPRET DIM & TOL PER ASME Y14.5M - 1994.
 REMOVE BURRS.
 COUNTERSINK INTERNAL THDS 90° TO MAJOR DIA.
 CHAM EXT THDS 45° TO MINOR DIA.
 THD LENGTHS AND DEPTHS ARE FOR MIN FULL THDS.
 DIMENSIONS APPLY AFTER FINISHING.

ALL MACHINED SURFACES. ⁶³✓
 TOTAL RUNOUT WITHIN .005.
 BREAK SHARP EDGES .005 TO .010.
 MACHINED FILLET RADII .005 TO .015.
 WELDING SYMBOLS PER AWS A2.4.
 ABBREVIATIONS PER MIL-STD-12.

UNLESS OTHERWISE SPECIFIED:
 DIMENSIONS ARE IN INCHES.
 DIMENSIONS IN BRACKETS [] ARE IN MILLIMETERS TOLERANCES ARE:

DECIMALS	METRIC	ANGLES
.XX ±.03	X ± 0.8	±1°
.XXX ±.010	.XX ±0.25	

APPROVALS		DATE
ORIG	RA	10/29/02
CHK	NC	10/29/02
APP	NC	10/29/02

DO NOT SCALE DRAWING

DYTRAN INSTRUMENTS, INC. Chatsworth, CA

MASTER ONLY IF IN RED

TITLE: **OUTLINE/INSTALLATION CABLE ASSEMBLY, BOOTED 2 PIN MILITARY, PLUG TO BNC**

SIZE B	CAGE CODE 2W033	DWG NO 127-6459A	REV B
---------------	------------------------	-------------------------	--------------

SCALE: 1:1 SHEET 1 OF 1