

PROPRIETARY AND CONFIDENTIAL

THE INFORMATION CONTAINED IN THIS DRAWING IS THE SOLE PROPERTY OF DYTRAN INSTRUMENTS INC. ANY REPRODUCTION IN PART OR AS A WHOLE WITHOUT THE WRITTEN PERMISSION OF DYTRAN INSTRUMENTS INC. IS PROHIBITED

REVISIONS

REV.	ECN	DESCRIPTION	BY/DATE	CHK	APPR
A	8356	INITIAL RELEASE	JS 03/09/12	LN	ANS
B	9399	SEE ECN	JS 12/26/12	RA	DV
C	14556	SEE ECN	AM 10/04/18	W	En

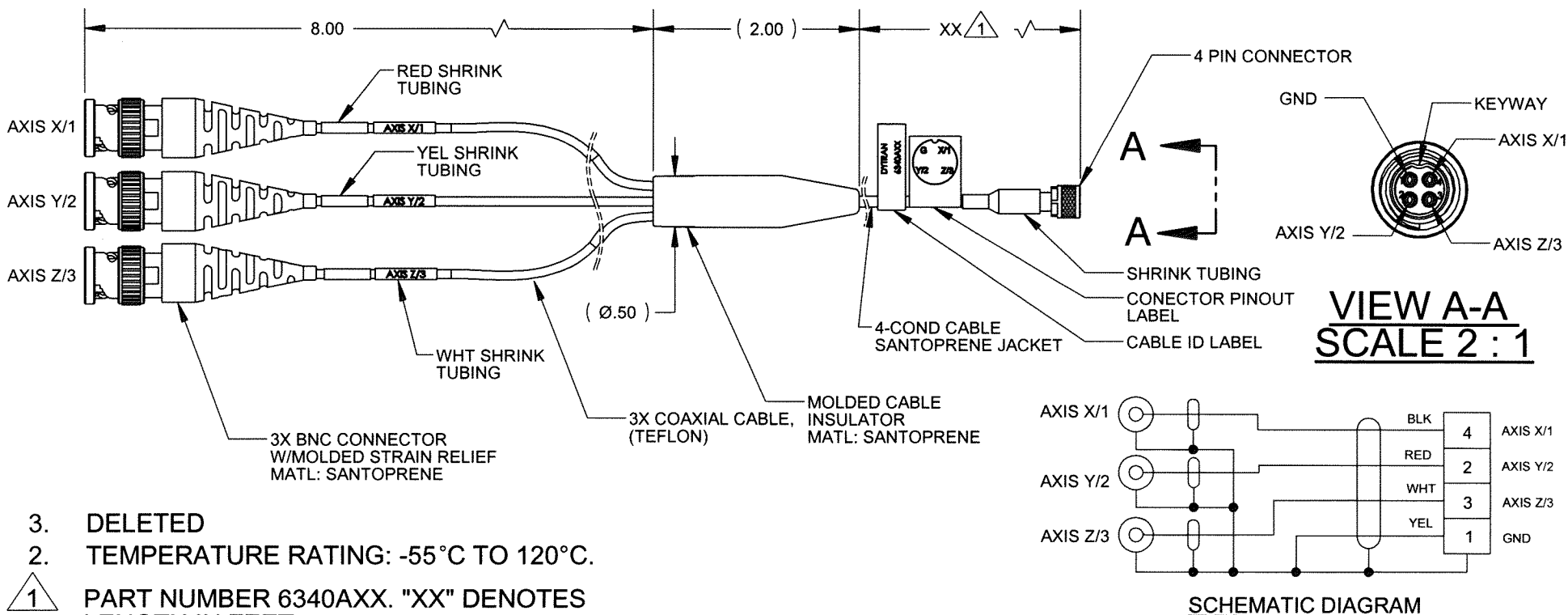

- 3. DELETED
- 2. TEMPERATURE RATING: -55°C TO 120°C.

$\triangle 1$ PART NUMBER 6340AXX. "XX" DENOTES LENGTH IN FEET.

NOTES: UNLESS OTHERWISE SPECIFIED.

6340A	
USED ON	NEXT ASSY
APPLICATION	
THIRD ANGLE PROJECTION USA	

UNLESS OTHERWISE SPECIFIED:
 INTERPRET DIM & TOL PER ASME Y14.5M - 1994.
 REMOVE BURRS.
 COUNTERSINK INTERNAL THDS 90° TO MAJOR DIA.
 CHAM EXT THDS 45° TO MINOR DIA.
 THD LENGTHS AND DEPTHS ARE FOR MIN FULL THDS.
 THDS PER MIL-S-7742.
 DIMENSIONS APPLY AFTER FINISHING.

ALL MACHINED SURFACES $\sqrt{63}$
 TOTAL RUNOUT WITHIN .005.
 BREAK SHARP EDGES .005 TO .010.
 MACHINED FILLET RADII .005 TO .015.
 WELDING SYMBOLS PER AWS A2.4.
 ABBREVIATIONS PER MIL-STD-12.

UNLESS OTHERWISE SPECIFIED:
 DIMENSIONS ARE IN INCHES. DIMENSIONS IN BRACKETS [] ARE IN MILLIMETERS
 TOLERANCES ARE:
 INCHES METRIC ANGLES
 .XX ± .03 .X ± 0.8 ± 1°
 .XXX ± .010 .XX ± 0.25

MATERIAL

FINISH

DO NOT SCALE DRAWING

CONTRACT NO.		
APPROVALS		DATE
ORIG	JS	03/09/12
CHK	LN	03/09/12
APP	ANS	03/09/12
APP		

MASTER COPY ONLY IF IN RED

Chatsworth, CA

TITLE:
**OUTLINE/INSTALLATION DRAWING,
 MINI 4 PIN TO (3) BNC, MODEL 6340A**

SIZE	CAGE CODE	DWG. NO.	REV
A	2W033	127-6340A	C

SCALE: NONE SOLIDWORKS SHEET 1 OF 1