

PROPRIETARY AND CONFIDENTIAL

THE INFORMATION CONTAINED IN THIS DRAWING IS THE SOLE PROPERTY OF DYTRAN INSTRUMENTS INC. ANY REPRODUCTION IN PART OR AS A WHOLE WITHOUT THE WRITTEN PERMISSION OF DYTRAN INSTRUMENTS INC. IS PROHIBITED

REVISIONS

REV	ECN	DESCRIPTION	BY/DATE	CHK	APPR
A	15364	INITIAL RELEASE, SAME AS X1	DP 10/09/19	KG	WS

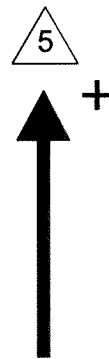
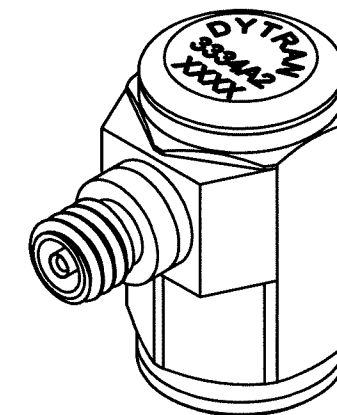
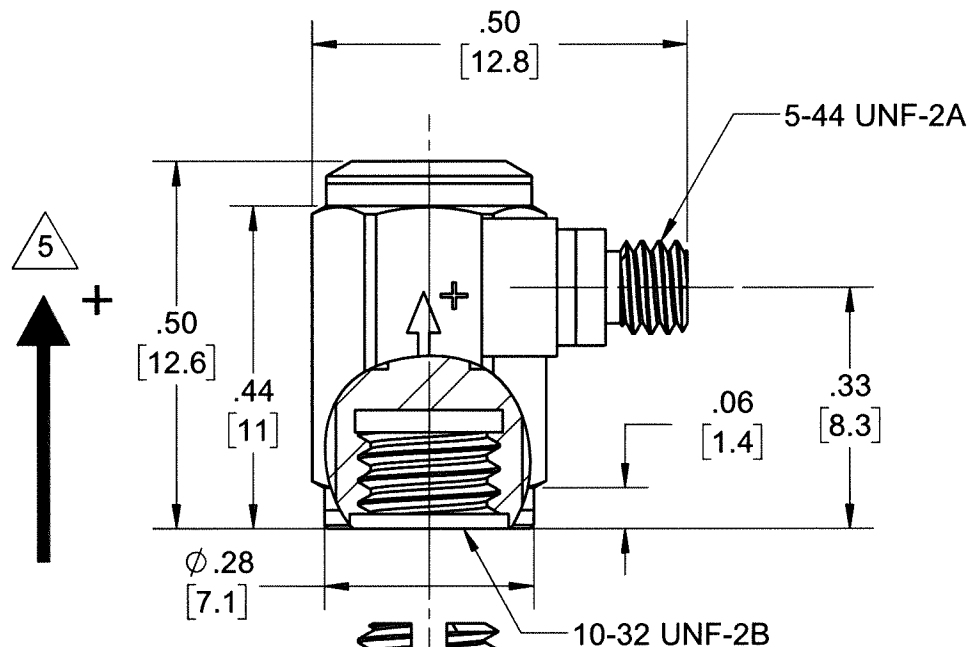
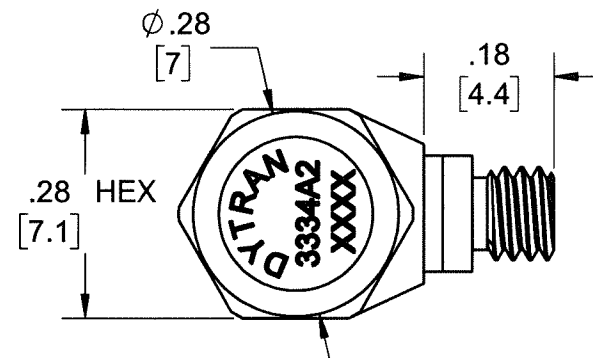

6200 STUD, SUPPLIED.

RECOMMENDED MOUNTING PREPARATION:
PREPARE MIN ϕ .30 [7.6] SURFACE FLAT TO .001 TIR.
TAP 10-32 UNF-2B ∇ .20 [5.1] MIN.

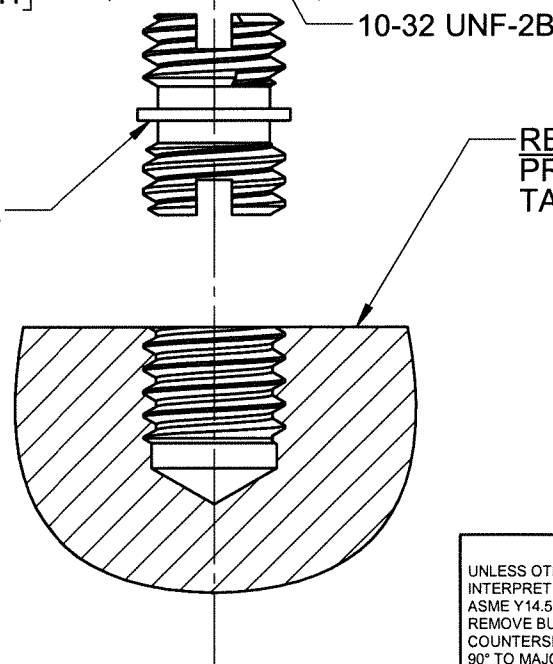

5 ARROW INDICATES SENSE AND DIRECTION FOR POSITIVE OUTPUT.

4. TEMPERATURE RANGE : -320°F TO +250°F
(-196°C TO 121°C)

3. MOUNTING TORQUE: 10-12 LB-IN.

2. SENSITIVITY: 10mV/G \pm 10%.

1. WEIGHT: 4 GRAMS, MAX.

NOTES: UNLESS OTHERWISE SPECIFIED

UNLESS OTHERWISE SPECIFIED:
INTERPRET DIM & TOL PER ASME Y14.5M - 1994.
REMOVE BURRS.
COUNTERSINK INTERNAL THDS 90° TO MAJOR DIA.
CHAM EXT THDS 45° TO MINOR DIA.
THD LENGTHS AND DEPTHS ARE FOR MIN FULL THDS.
DIMENSIONS APPLY AFTER FINISHING.

ALL MACHINED SURFACES.
TOTAL RUNOUT WITHIN .005.
BREAK SHARP EDGES .005 TO .010.
MACHINED FILLET RADII .005 TO .015.
WELDING SYMBOLS PER AWS A2.4.
ABBREVIATIONS PER MIL-STD-12.

UNLESS OTHERWISE SPECIFIED:
DIMENSIONS ARE IN INCHES.
DIMENSIONS IN BRACKETS [] ARE IN MILLIMETERS TOLERANCES ARE:
DECIMALS METRIC
.XX \pm .03 X \pm 0.8 ANGLES
.XXX \pm .010 .XX \pm 0.25 \pm 1°

APPROVALS		DATE
ORIG	LN	11/20/18
CHK	KG	10/11/19
APP	WS	10/16/19
DO NOT SCALE DRAWING		

DYTRAN INSTRUMENTS, INC. Chatsworth, CA

MASTER ONLY IF IN RED

TITLE: **OUTLINE/INSTALLATION DRAWING, MODEL 3334A2**

SIZE B	CAGE CODE 2W033	DWG NO 127-3334A2	REV A
---------------	------------------------	--------------------------	--------------

SCALE: 4:1 SHEET 1 OF 1



- CRYOGENIC
- MINIATURE SIZE
- HERMETICALLY SEALED

PHYSICAL

Weight, Max. Type
 Connector
 Mounting Provision
 Material, Housing/Connector
 Sensing Element

ENGLISH		SI	
0.14	oz	4.0	grams
5-44 UNF-2A		5-44 UNF-2A	
10-32 Tapped Hole		10-32 Tapped Hole	
Titanium		Titanium	
Quartz		Quartz	

PERFORMANCE

Sensitivity, ±10% [1]
 Range F.S for ±5V Output
 Frequency Range, ± 5%
 Frequency Range, ± 10%
 Resonant Frequency
 Equivalent Electrical Noise Floor [4]
 Linearity [2]
 Maximum Transverse sensitivity
 Strain Sensitivity @ 250µε

10	mV/g	1	mV/m/s ²
500	Gpeak	4905	m/s ² peak
1.2 to 6000	Hz	1.2 to 6000	Hz
1.0 to 10000	Hz	1.0 to 10000	Hz
> 45	kHz	> 45	kHz
0.007	Grms	0.07	m/s ² rms
±1	% F.S.	±1	% F.S.
5	%	5	%
0.002	g/µε	0.02	m/s ² /µε

ENVIRONMENTAL

Maximum Vibration
 Maximum Shock
 Temperature Range
 Coefficient of Thermal Sensitivity
 Seal

600	Gpeak	5886	m/s ² peak
3000	Gpeak	29430	m/s ² peak
-320 to +250	°F	-196 to 121	°C
0.03	%/°F	0.05	%/°C
Hermetic		Hermetic	

ELECTRICAL

Supply Current Range [3]
 Compliance Voltage Range
 Output Impedance, Typ
 Bias Voltage
 Discharge Time Constant
 Electrical Isolation

2 to 20	mA	2 to 20	mA
+18 to +30	Volts	+18 to +30	Volts
100	Ω	100	Ω
+7.0 to +9.0	VDC	+7.0 to +9.0	VDC
0.4 to 1.5	Sec	0.4 to 1.5	Sec
Case Grounded		Case Grounded	

This family also includes:

Model	Sensitivity (mV/g)	Frequency Response (Hz)	Time Constant (Sec)	Operating Temp (°F)

Refer to the performance specifications of the products in this family for detailed description

Supplied Accessories:

- 1) Accredited calibration certificate (ISO 17025)
- 2) Mounting stud, 6200, 10-32 to 10-32. Qty: 1.

Notes:

- [1] Measured at 100Hz, 1 Grms per ISA RP 37.2.
- [2] Measured using zero-based straight line method, % of F.S. or any lesser range.
- [3] Do not apply power to this system without current limiting, 20 mA MAX. To do so will destroy the IC amplifier.
- [4] Typical. Not to exceed 0.010 Grms [0.10 m/s²]
- [5] In the interest of constant product improvement, we reserve the right to change specifications without notice. It is the customer's responsibility to validate that a particular product with the properties described in the product specification is suitable for use in a particular application. Parameters provided in datasheets and / or specifications may vary in different applications and performance may vary overtime. All operating parameters, including typical parameters, must be validated for each customer application by the customer's technical experts.

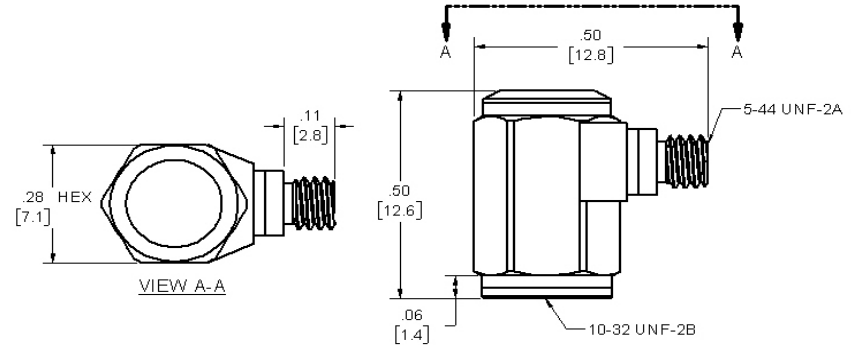
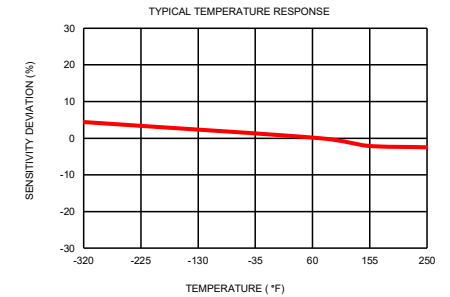
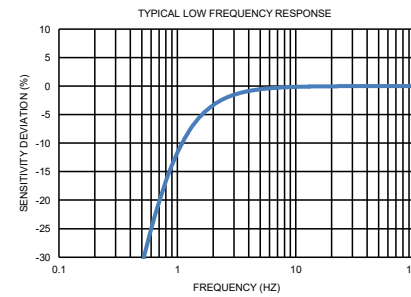

Units on the line drawing are in inches, units in brackets are in millimeters. Refer to 127-3334A2 for more information.

