

PROPRIETARY AND CONFIDENTIAL

THE INFORMATION CONTAINED IN THIS DRAWING IS THE SOLE PROPERTY OF DYTRAN INSTRUMENTS INC. ANY REPRODUCTION IN PART OR AS A WHOLE WITHOUT THE WRITTEN PERMISSION OF DYTRAN INSTRUMENTS, INC. IS PROHIBITED

REVISIONS

REV	ECN	DESCRIPTION	BY/DATE	CHK	APPR
F	15401	PIN A-, B+, WAS: PIN A+, B-	RA 11/07/19		

MODEL	SENSITIVITY	WEIGHT MAX.
3235C1	50pC/G	69 GRAMS
3235C2	100pC/G	72 GRAMS
3235C3	200pC/G	85 GRAMS

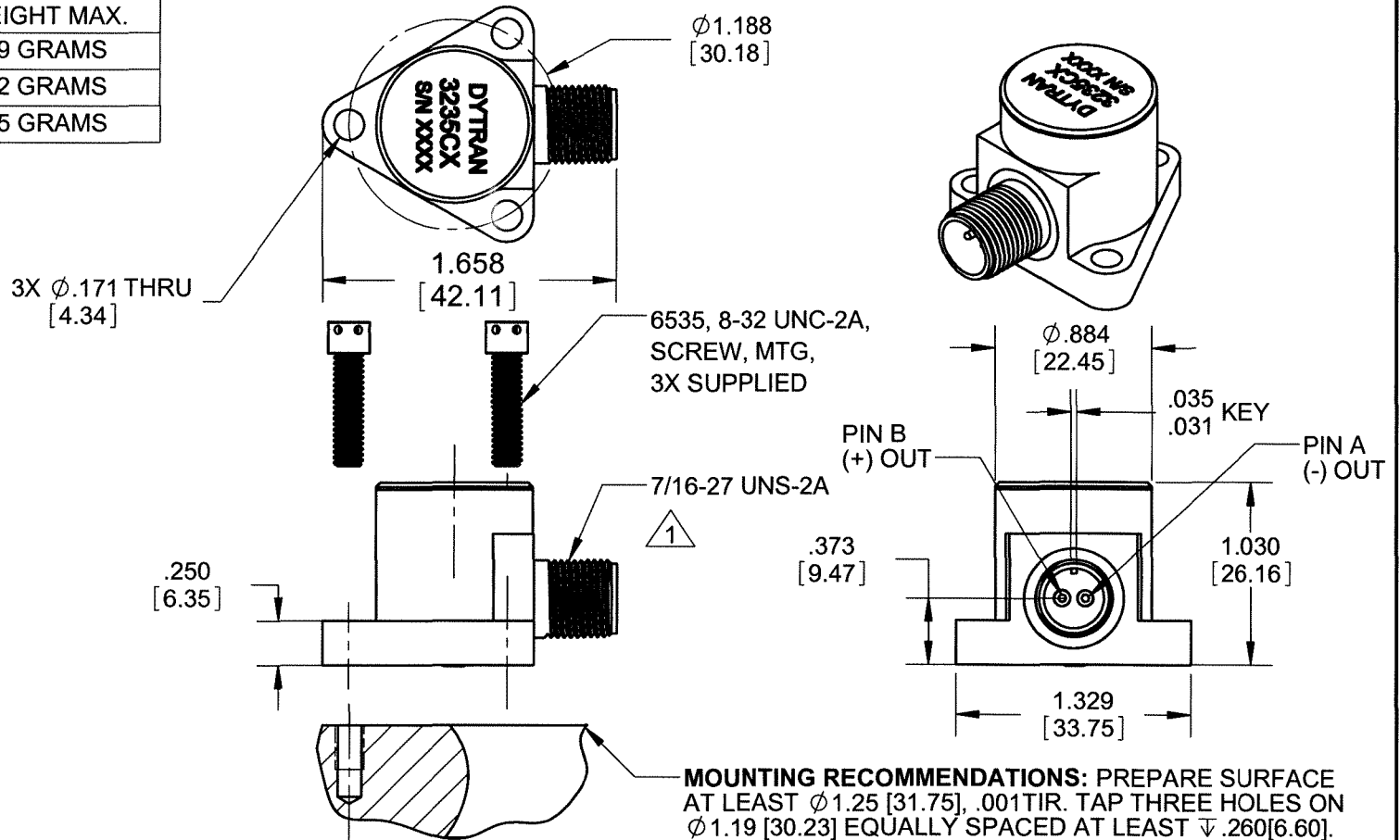

2. CASE MATERIAL: 304L

1 MATES WITH GLENAIR G345-1 PLUG

NOTES: UNLESS OTHERWISE SPECIFIED

UNLESS OTHERWISE SPECIFIED: INTERPRET DIM & TOL PER ASME Y14.5M - 1994. REMOVE BURRS. COUNTERSINK INTERNAL THDS 90° TO MAJOR DIA. CHAM EXT THDS 45° TO MINOR DIA. THD LENGTHS AND DEPTHS ARE FOR MIN FULL THDS. THDS PER MIL-S-7742. DIMENSIONS APPLY AFTER FINISHING.	UNLESS OTHERWISE SPECIFIED: DIMENSIONS ARE IN INCHES. DIMENSIONS IN BRACKETS ARE IN MILLIMETERS. TOLERANCES ARE: DECIMALS ANGLES INCH METRIC .XX ± .03 .X ± 0.8 .XXX ± .010 .XX ± 0.25
USED ON APPLICATION	NEXT ASSY APPLICATION
THIRD ANGLE PROJECTION USA	
ALL MACHINED SURFACES. TOTAL RUNOUT WITHIN .005. BREAK SHARP EDGES .005 TO .010. MACHINED FILLET RADII .005 TO .015. WELDING SYMBOLS PER AWS A2.4. ABBREVIATIONS PER MIL-STD-12	

CONTRACT NO.	
APPROVALS	DATE
ORIG JS	07/01/09
CHK EP	01/25/10
APP DV	01/28/10
APP	
DO NOT SCALE DRAWING	

DYTRAN INSTRUMENTS, INC. Chatsworth, CA **MASTER ONLY IF IN RED**

TITLE: **OUTLINE/INSTALLATION DRAWING 3235C**

SIZE A	CAGE CODE 2W033	DWG. NO. 127-3235C	REV F
SCALE: 1:1	SOLIDWORKS	SHEET 1 OF 1	

MODEL NUMBER	PERFORMANCE SPECIFICATION		DOC NUMBER PS3235C1
3235C1	Accelerometer, Single Axis Differential, Charge Mode		REV D, ECN 14094, 03/13/18



Actual Size

- **HIGH-TEMPERATURE OPERATION**
- **HIGH CHARGE SENSITIVITY**
- **EXTREME STABILITY OVER TEMPERATURE**
- **BALANCED DIFFERENTIAL OUTPUT**

PHYSICAL

	ENGLISH		SI	
Weight, Max	1.9	oz	69	grams
Size	1.65	inch	42.11	mm
	1.03	inch	26.16	mm
Mounting, Three-hole	1.19	inch	30.23	mm
Connector[1]	St. Steel		St. Steel	
	2-Pin		2-Pin	
Housing	304L		304L	
Isolation	10GΩ MIN		10GΩ MIN	
Sensing Element	Ceramic		Ceramic	
	Mode		Compression	

PERFORMANCE

Sensitivity [2] +/-5%	50	pC/g	5.10	pC/m/s ²
Acceleration Range	[3]	Gpeak	[3]	m/s ² peak
Frequency Range, ±15%	[4] - 10,000	Hz	[4]- 10,000	Hz
Resonance Frequency	35	kHz	35	kHz
Transverse Sensitivity	5	%	5	%
Insulation Resistance (75°F)	250	GΩ	250	GΩ
Insulation Resistance (400°F)	10	GΩ	10	GΩ
Insulation Resistance (450°F)	100	MΩ	100	MΩ
Insulation Resistance (550°F)[5]	15	MΩ	15	MΩ
Operating Temperature	-60 to 550	°F	-51 to 287	°C
Capacitance, pin to pin	3200	pF	3200	pF
Unbalance between pins	<2	pF	<2	pF
Linearity	1	%	1	%

ENVIRONMENTAL

Shock, MAX	2000	g pk	19620	m/s ²
Vibration, MAX	1000	g pk	9810	m/s ²
Seal	Hermetic		Hermetic	
Magnetic Sensitivity at 100 Gauss	0.000008	g/Gauss	0.000078	m/s ² /Gauss
Base Strain Sensitivity	0.09	g/με	0.88	m/s ² /με
Radiation Exposure Limit (Integrated Neutron Flux)	1.0E+10	N/cm ²	1.0E+10	N/cm ²
Radiation Exposure Limit (Integrated Gamma Flux)	1.0E+08	rad	1.0E+08	rad

This family also includes:

Model	Sensitivity (pC/g)	Range (Gpeak)	Oper. Temp(°F)
3235C2	100	[3]	-60 to 550[5]
3235C3	200	[3]	-60 to 550[5]

Please, refer to the performance specifications of the products in this family for detailed description

Supplied Accessories:

- 1) Model 6535 Mounting Screw, 8-32 thread (3)
- 2) Accredited Calibration Certificate (ISO 17025)

Notes:

- [1] 2-Pin, Glass-To-Metal Seal connector. Mates With Glenair G345-1 Plug.
- [2] Actual Sensitivity Is Given On A Calibration Certificate
- [3] Depends On the Gain Setting Of The Charge Amplifier Used
- [4] Low Frequency Response Is the Function Of the Discharge Time Constant Of The Charge Amplifier Used. Please, Refer To The Plot Below For Frequency Response For Different Time Constants
- [5] The unit is able to withstand short exposure of 600F temperature
- [6] In the interest of constant product improvement, we reserve the right to change specifications without notice.

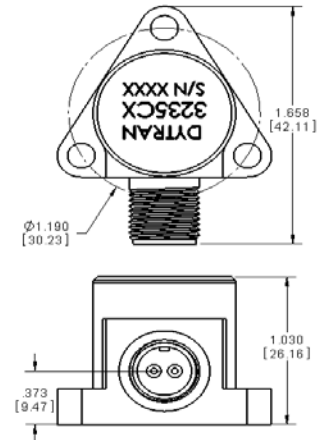
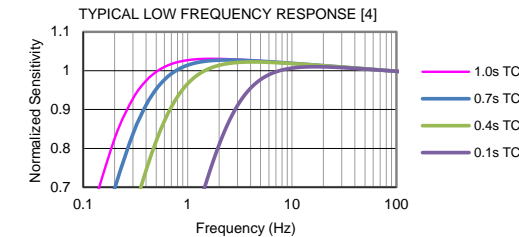
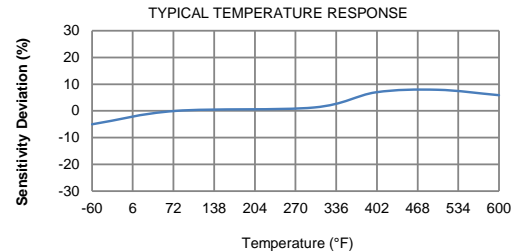

Units on the line drawing are in inches, units in brackets are in millimeters. Refer to 127-3235C for more information.



21592 Marilla Street, Chatsworth, California 91311 Phone: 818.700.7818 Fax: 818.700.7880 www.dytran.com For permission to reprint this content, please contact info@dytran.com