

PROPRIETARY AND CONFIDENTIAL

THE INFORMATION CONTAINED IN THIS DRAWING IS THE SOLE PROPERTY OF DYTRAN INSTRUMENTS INC. ANY REPRODUCTION IN PART OR AS A WHOLE WITHOUT THE WRITTEN PERMISSION OF DYTRAN INSTRUMENTS INC. IS PROHIBITED

MODEL NO	REV	ECN	DATE	SENSITIVITY
2006M1	B	11209	07/30/14	1000 mV/psi
2006M2	A	11209	07/30/14	300 mV/psi

REVISIONS

REV	ECN	DESCRIPTION	BY/DATE	CHK	APPR
B	11209	UPDATED HOUSING MAT'L CALL OUT NOTE. ADDED FLAG NOTE 8	EC 08/27/14	<i>DV</i>	<i>AS</i>

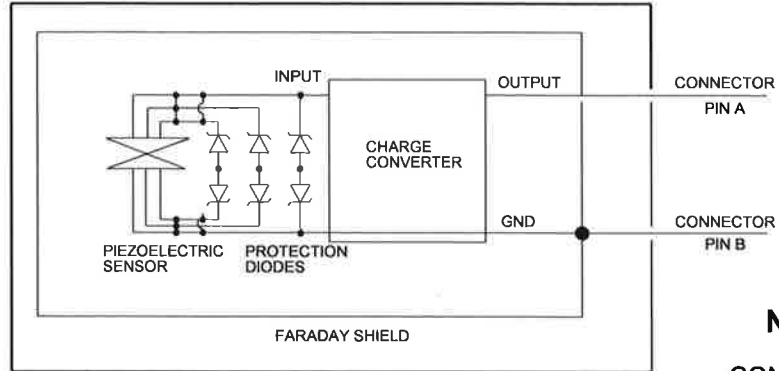

HOUSING SCHEMATIC DIAGRAM

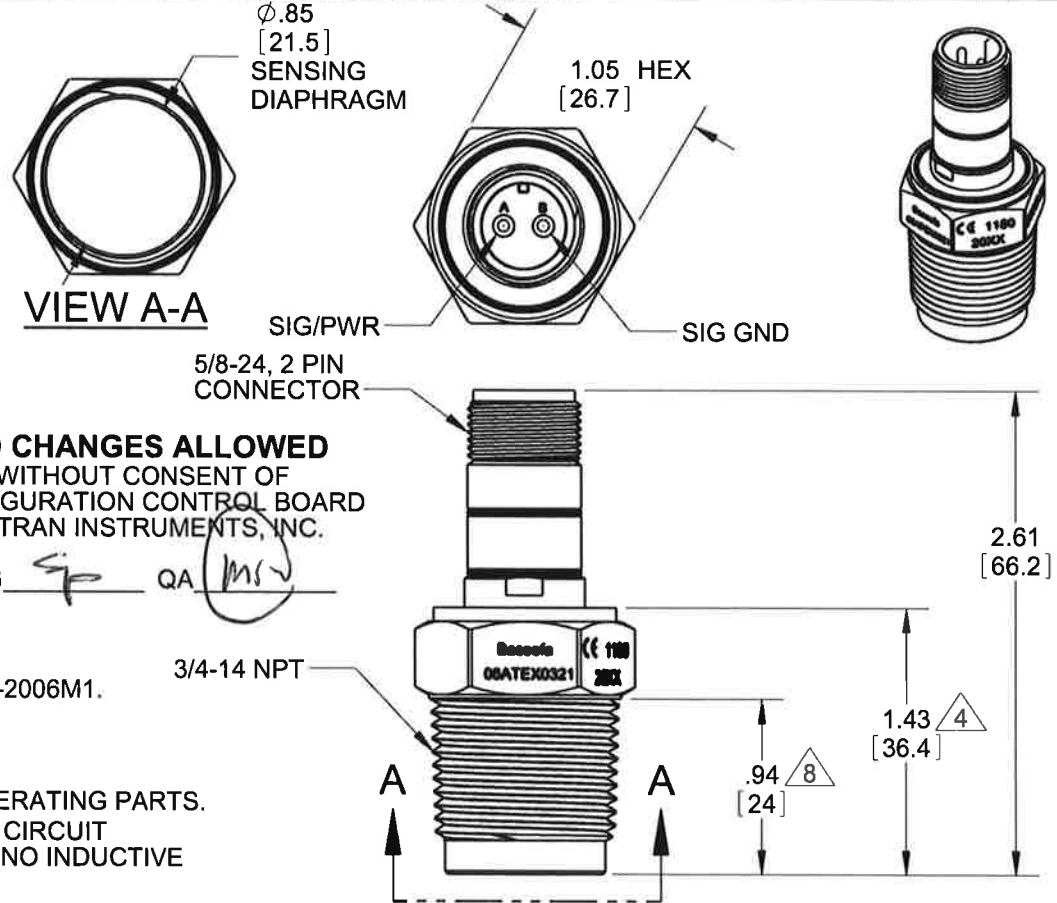

NO CHANGES ALLOWED
WITHOUT CONSENT OF
CONFIGURATION CONTROL BOARD
DYTRAN INSTRUMENTS, INC.

ENG *SP* QA *MSV*

- 8. EXPOSED TO MEDIA
- 7. SIGNAL GROUND TO CASE ISOLATION > 100MOhms
- 6. STRUCTURAL JOINTS ARE TIG WELDED PER DRAWING 178-2006M1.
- 5. CONNECTOR MATERIAL: 300 SERIES STAINLESS STEEL
- 4. HOUSING MATERIAL: 316L SERIES STAINLESS STEEL
- 3. CHARGE CONVERTER HAS NO VOLTAGE ENHANCING/GENERATING PARTS.
- 2. TOTAL SENSOR CAPACITANCE, Ci (PIEZO ELEMENTS PLUS CIRCUIT CAPACITORS): 8800pF MAXIMUM, THIS SENSOR CONTAINS NO INDUCTIVE COMPONENTS
- 1. DIODES: 43V±5%max, >500mW, DO-35 ZENER

NOTES: UNLESS OTHERWISE SPECIFIED

UNLESS OTHERWISE SPECIFIED: INTERPRET DIM & TOL PER ASME Y14.5M - 1994. REMOVE BURRS. COUNTERSINK INTERNAL THDS 90° TO MAJOR DIA. CHAM EXT THDS 45° TO MINOR DIA. THD LENGTHS AND DEPTHS ARE FOR MIN FULL THDS. THDS PER MIL-S-7742. DIMENSIONS APPLY AFTER FINISHING.	
2006M1	63
USED ON	NEXT ASSY
APPLICATION	
THIRD ANGLE PROJECTION USA	
ALL MACHINED SURFACES. TOTAL RUNOUT WITHIN .005. BREAK SHARP EDGES .005 TO .010. MACHINED FILLET RADII .005 TO .015. WELDING SYMBOLS PER AWS A2.4. ABBREVIATIONS PER MIL-STD-12.	

UNLESS OTHERWISE SPECIFIED: DIMENSIONS ARE IN INCHES. DIMENSIONS IN BRACKETS [] ARE IN MILLIMETERS TOLERANCES ARE: INCHES METRIC ANGLE .XX ± .03 .X ± 0.8 ± 1° .XXX ± 0.10 .XX ± 0.25	
MATERIAL	SEE NOTES
FINISH	
DO NOT SCALE DRAWING	

CONTRACT NO.	
APPROVALS	
ORIG	RA
CHK	DV
APP	AS
DATE	09/13/12
	10/12/12
	10/12/12

DYTRAN INSTRUMENTS, INC. **MASTER** Chatsworth, CA **ONLY IN RED**

TITLE: **OUTLINE/INSTALLATION DRAWING, MODEL 2006M1**

SIZE	CAGE CODE	DWG. NO.	REV
A	2W033	127-2006M1	B

SCALE: NONE SOLIDWORKS SHEET 1 OF 1

MODEL NUMBER 2006M1	PERFORMANCE SPECIFICATION	DOC NO. PS2006M1
--------------------------------------	----------------------------------	-----------------------------------

ACOUSTIC PRESSURE SENSOR, IEPE		REV C , ECN 12560 , 03/25/16
---------------------------------------	--	------------------------------



- HIGH INTENSITY ACOUSTIC SENSOR
- HIGH SENSITIVITY
- INTERNALLY GROUND ISOLATED
- HERMETICALLY SEALED

PHYSICAL

Weight, Max
Mounting Provision
Connector
Body/Diaphragm
Connector

	ENGLISH		SI	
Weight, Max	4.7	oz	135	grams
Mounting Provision	3/4-14 NPT		3/4-14 NPT	
Connector	5/8-24, 2-PIN		5/8-24, 2-PIN	
Body/Diaphragm	300 Series Stainless Steel		300 Series Stainless Steel	
Connector	300 Series Stainless Steel		300 Series Stainless Steel	

PERFORMANCE

Sensitivity +/- 6% [3]	1000	mV/psi	0.145	mV/Pa
Range F.S for 5 volts peak out	5	psi	34474	Pa
Absolute Maximum Pressure [4]	5075	psi	35	MPa
Equivalent Electrical Noise (Resolution)	1.00E-05	psi	0.0689	Pa
Mounted Resonant Frequency	> 21	kHz	> 21	kHz
Frequency Response, +/- 5%	2500	Hz	2500	Hz
Minimum Rise Time of Input Pulse	5	µsec	5	µsec
Discharge Time Constant	0.6 to 1.5	sec	0.6 to 1.5	sec
Linearity [1]	+/-1	%F.S	+/-1	%F.S
Lower -3db Frequency	0.25	Hz	0.25	Hz
Lower 10% Frequency	0.5	Hz	0.5	Hz

ENVIRONMENTAL

Maximum Vibration	100	g rms	981	m/s ² rms
Maximum Shock	500	g pk	4905	m/s ² peak
Temperature Range	-60 to +250	°F	-51 to +121	°C
Thermal Coefficient Of Sensitivity	0.06	% / °F	0.11	% / °C
Environmental Seal	Hermetic		Hermetic	

ELECTRICAL

Excitation Voltage Range [2]	+20 to +30	VDC	+20 to +30	VDC
Excitation Current Range [2]	2 to 20	mA	2 to 20	mA
Output Impedance, NOM	150	Ω	150	Ω
Output Bias Voltage	11 to 13	VDC	11 to 13	VDC
Output Signal Polarity For Increasing Pressure	Positive		Positive	

This family also includes:

Model	Sensitivity (mV/psi)	Range (psi pk)	Resolution (Grms)	Oper. Temp(°F)	TC (Sec)
2006M2	300	16.5	3.00E-05	-60 to +250	0.6 to 1.5

Please, refer to the performance specifications of the products in this family for detailed description.

NOTES:

- [1] Percent full scale, zero based fit straight line method.
- [2] From constant current type power unit only. This sensor MUST NOT BE CONNECTED to a DC power source without current limiting, 20mA Maximum.
- [3] A calibration certificate traceable to NIST is supplied with each instrument.
- [4] Full pressure must be applied gradually. Do not exceed 100psi/ sec.

CERTIFICATIONS:

ATEX Ex II 1G Ex ia IIC T4 Ga (marked on each microphone)
Baseefa06ATEX0321 (marked on each microphone)
CE certified (marked on each microphone) **CE**

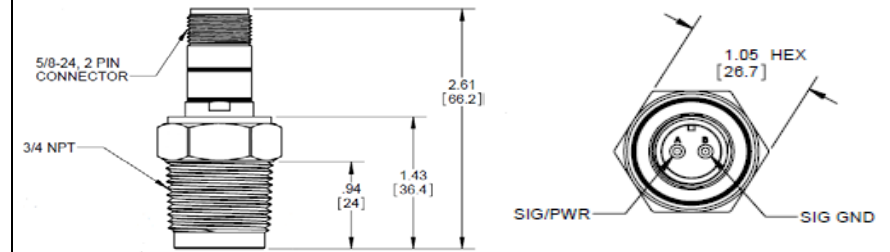
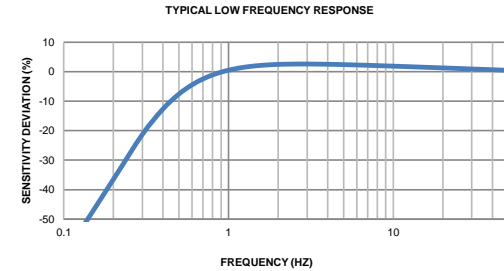

Dimensions in brackets are in millimeters. Refer to 127-2006M1 for more information.



21592 Marilla Street, Chatsworth, California 91311 Phone: 818.700.7818 Fax:818.700.7880
www.dytran.com For permission to reprint this content, please contact info@dytran.com