

DYTRAN PROPRIETARY AND CONFIDENTIAL			
THE INFORMATION CONTAINED IN THIS DRAWING IS THE SOLE PROPERTY OF DYTRAN INSTRUMENTS, INC. AND ANY REPRODUCTION IN PART OR AS A WHOLE OR ANY OTHER DISSEMINATION OF THIS INFORMATION WITHOUT THE WRITTEN PERMISSION OF DYTRAN INSTRUMENTS, INC. IS PROHIBITED.			
MODEL	SENSITIVITY	TC (SEC)	RANGE F.S.
1203V1	50 mV/Lb	90	100 Lb
1203V2	10 mV/Lb	450	500 Lb
1203V3	5 mV/Lb	850	1000 Lb
1203V4	1 mV/Lb	1800	5000 Lb
1203V5	0.5 mV/Lb	1800	10,000 Lb

REV	ECN	DESCRIPTION	BY/DATE	CHK	APPR
A	8074	UPDATED FORMAT	RA, 11/17/11	JS	<i>[Signature]</i>

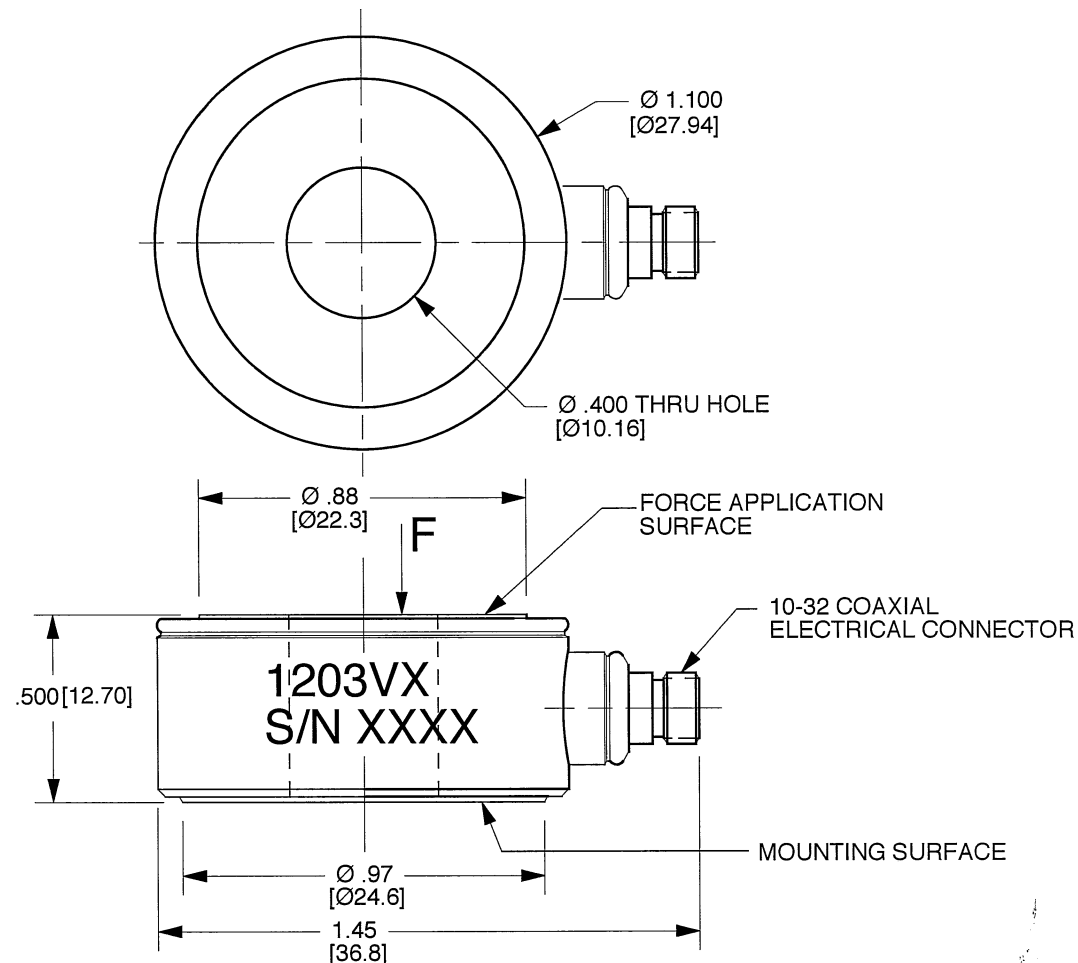

4. WEIGHT: 50 GRAMS.
3. ENVIRONMENTAL SEAL: HERMETIC.
2. MATERIAL: LOAD-BEARING SURFACES: HARDENED 17-4 PH STAINLESS STEEL. HOUSING AND CONNECTOR: 300 SERIES STAINLESS STEEL.
1. POLARITY: POSITIVE-GOING WITH COMPRESSION.

NOTES: UNLESS OTHERWISE SPECIFIED

USED ON	NEXT ASSY	UNLESS OTHERWISE SPECIFIED: INTERPRET DIM & TOL PER ASME Y14.5M-1994. REMOVE BURRS COUNTERSINKS INTERNAL THDS 90° TO MAJOR DIA. THD EXT THDS 45° TO MAJOR DIA. THD LENGTHS AND DEPTHS ARE FOR THDS PER MIL-S-7742. DIMENSIONS APPLY AFTER FINISHING.
APPLICATION		
THIRD ANGLE PROJECTION USA		
		ALL MACHINED SURFACES $\sqrt{63}$ TOTAL RUNOUT WITHIN .005 BREAK SHARP EDGES .005 TO .010 MACHINE FILLET RADI .005 TO .015. WELDING SYMBOLS PER AWS A2.4 ABBREVIATIONS PER MIL-STD-12

CONTRACT NO		
UNLESS OTHERWISE SPECIFIED DIMENSIONS ARE IN INCHES. DIMENSION IN BRACKETS [] ARE IN MILLIMETERS. TOLERANCES ARE:		
INCHES	METRIC	ANGLES
.XX ±.03	.X ± 0.8	± 1°
.XXX ±.010	.XX ± 0.25	
FINISH		
DO NOT SCALE DRAWING		

		MASTER ONLY IF IN RED		CHATSWORTH, CA.	
SCALE	DESIGN	DATE			
2X	NC	10-10-07			
DRAWN	DATE	PART NO.	MODEL SERIES 1203V		
NC	12/17/01				
CHECKED	DATE	MAT'L			REV
R.A.	08/01/06	-			A
APPROVED	DATE	NEXT ASSEMBLY	USED ON	SERIES 1203V	
N.C.	08/01/06	-			
TITLE			DWG NO.		
OUTLINE/INSTALLATION DRAWING, MODEL SERIES 1203V FORCE SENSORS			127-1203V		
			SHEET 1 OF 1		



- RING STYLE FORCE SENSOR
- HERMETICALLY SEALED
- EXCELLENT LINEARITY

PHYSICAL

Weight, Max.	10-32	oz	Type	10-32	grams
Connector [1]			Material	Stainless steel	
Housing			Material	Stainless steel	
Sensing Element			Isolation	Case grounded	
			Material	Quartz	
			Mode	Compression	

ENGLISH

SI

PERFORMANCE

Sensitivity, ± 10 %	10	mV/Lb	2.47	mV/N
Compression Range	500	Lb Force	2.22	kN
Maximum Compression	1,000	Lb Force	4.45	kN
Discharge Time Constant	450	Seconds	450	Seconds
Broadband Resolution	0.00014	Lb, rms	6.23E-07	kN, rms
Maximum Unloaded Shock	10,000	g's	98,100	m/s^2
Maximum Unloaded Vibration	5,000	g's, Peak	49,050	m/s^2 Peak
Linearity [2]	± 1	% Full Scale	± 1	% Full Scale
Resonant Frequency	>75	kHz	>75	kHz
Stiffness	20	Lb/µin	3.46	kN/µm
Preload	2000	Lb Force	8.90	kN

10	mV/Lb	2.47	mV/N
500	Lb Force	2.22	kN
1,000	Lb Force	4.45	kN
450	Seconds	450	Seconds
0.00014	Lb, rms	6.23E-07	kN, rms
10,000	g's	98,100	m/s^2
5,000	g's, Peak	49,050	m/s^2 Peak
± 1	% Full Scale	± 1	% Full Scale
>75	kHz	>75	kHz
20	Lb/µin	3.46	kN/µm
2000	Lb Force	8.90	kN

ENVIRONMENTAL

Coefficient Of Thermal Sensitivity	0.03	%/°F	0.05	%/°C
Operating Temperature	-100 to +250	°F	-73 to +121	°C
Environmental Seal	Hermetic		Hermetic	

0.03	%/°F	0.05	%/°C
-100 to +250	°F	-73 to +121	°C
Hermetic		Hermetic	

ELECTRICAL

Supply current	2 to 20	mA	2 to 20	mA
Voltage Range [3]	18 to 30	VDC	18 to 30	VDC
Full Scale Output Voltage	5	Volts	5	Volts
Output Impedence	<100	Ω	<100	Ω
Bias Voltage	7.5 to 9.5	VDC	7.5 to 9.5	VDC

2 to 20	mA	2 to 20	mA
18 to 30	VDC	18 to 30	VDC
5	Volts	5	Volts
<100	Ω	<100	Ω
7.5 to 9.5	VDC	7.5 to 9.5	VDC

This family also includes:

Model	Sensitivity (mV/Lb)	Range (Lbs.Force)	Max.Force (Lbs.Force)	Discharge T.C. (sec)
1203V1	50	100	200	90
1203V3	5	1,000	5,000	850
1203V4	1	5,000	10,000	1800
1203V5	0.5	10,000	15,000	1800

Please refer to the performance specifications of the products in this family for detailed description

Supplied Accessories:

- 1) Accredited calibration certificate (ISO 17025)

Notes:

- [1] Radially mounted with 10-32 receptacle micro coaxial connector
- [2] Percent of full scale or any lesser range, Zero based best-fit straight line method.
- [3] Power these instruments only with constant current type power units. Do not connect to a source of voltage without current limiting. This will destroy the integral IC amplifier.
- [4] In the interest of constant product improvement, we reserve the right to change specifications without notice. It is the customer's responsibility to validate that a particular product with the properties described in the product specification is suitable for use in a particular application. Parameters provided in datasheets and / or specifications may vary in different applications and performance may vary overtime. All operating parameters, including typical parameters, must be validated for each customer application by the customer's technical experts.

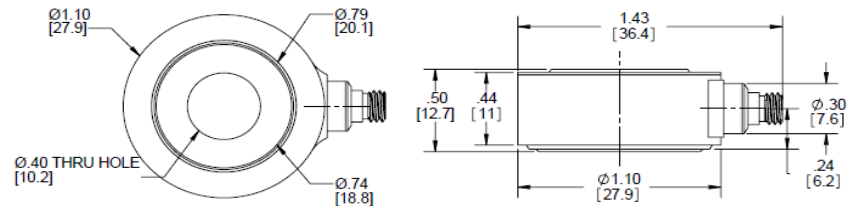
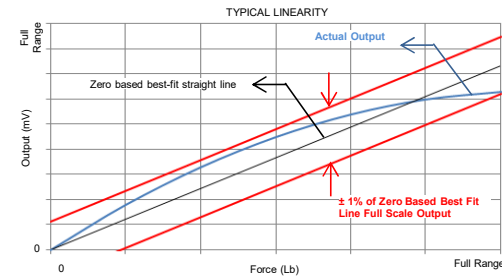

Units on the line drawing are in inches, units in brackets are in millimeters. Refer to 127-1203V for more information.

