

DYNALABS MODAL SHAKER(DYN-MS-440)

DYN-MS-440	
Output Force(Sinus)	440 N
Frequency Range	0-5 kHz
Displacement(P-P)	25 mm
Maximum Acceleration	100 g
Shaker Weight	11.8 kg
Cooling System	Forced Convection
Operating Temperature Range	5-35 °C
Suspension	Spring
Amplifier	External
Maximum Input Current	10A (RMS)
DYN-SA-1100	
Operation Voltage	110/220 VAC
Sine Freq. Generator	Activated by pulling out the gain knob
Sine Frequency Range	0-15 kHz
External Signal Voltage Level	10 VAC (PEAK)
Amplifier Weight	5.3 kg
DYN-BLW-511	
Frequency	50 Hz
Rated Power	0.8 kW
Input Voltage	230 V
Input Current	5.2 A
Blower Weight	15 kg

Stinger Set

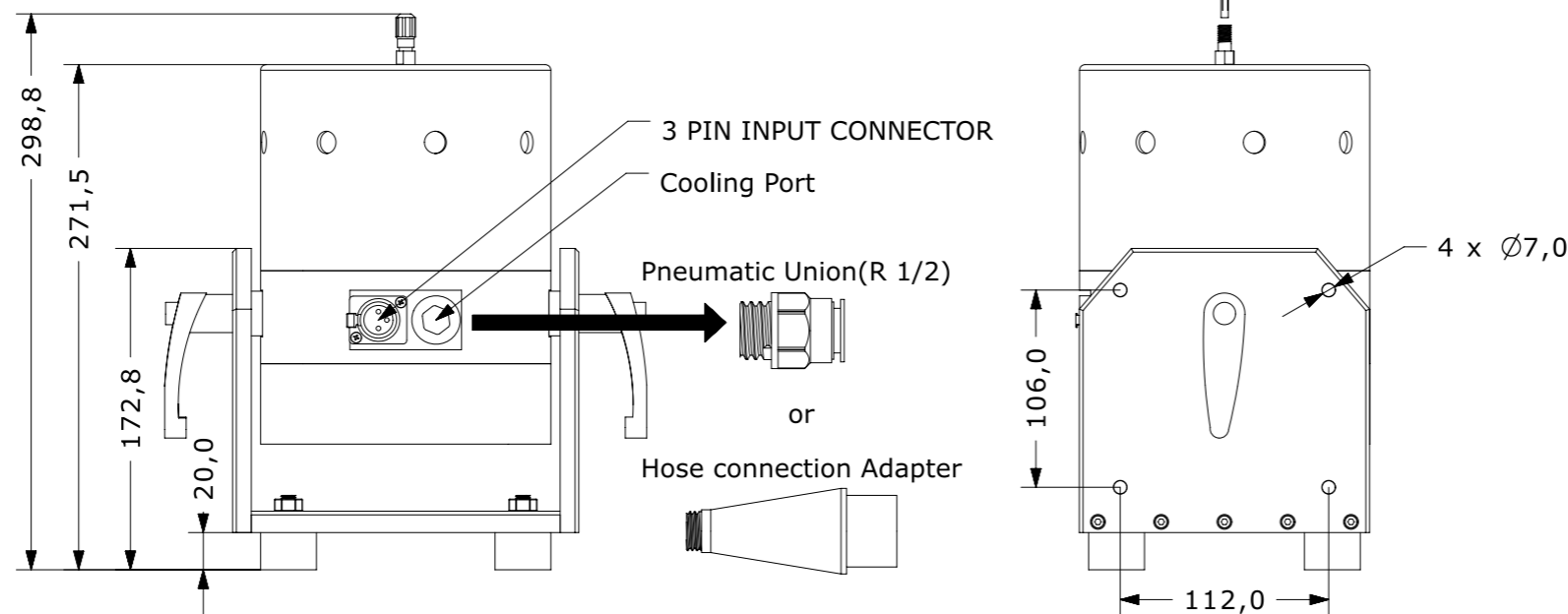
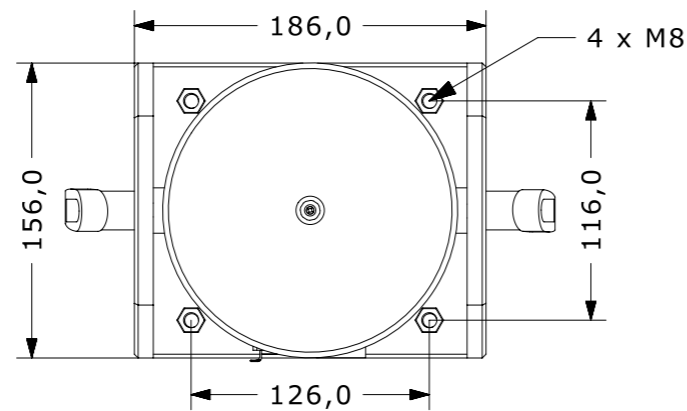
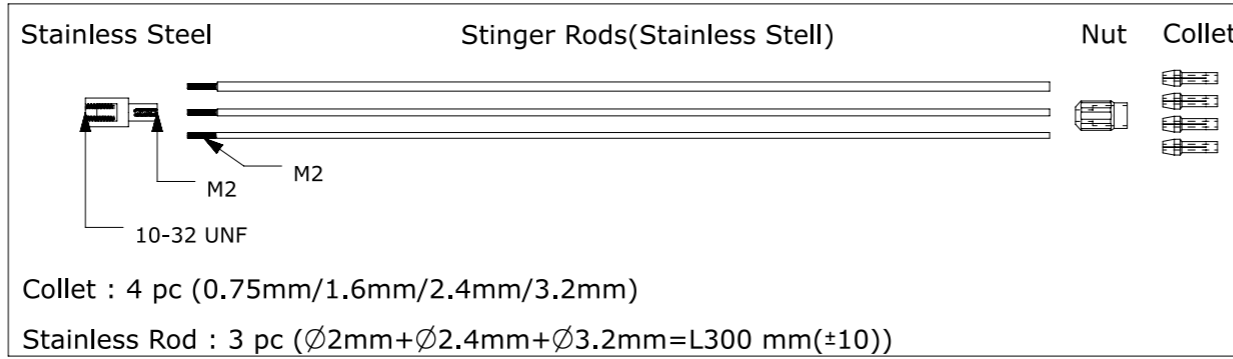

DYN-SA-1100 Amplifier

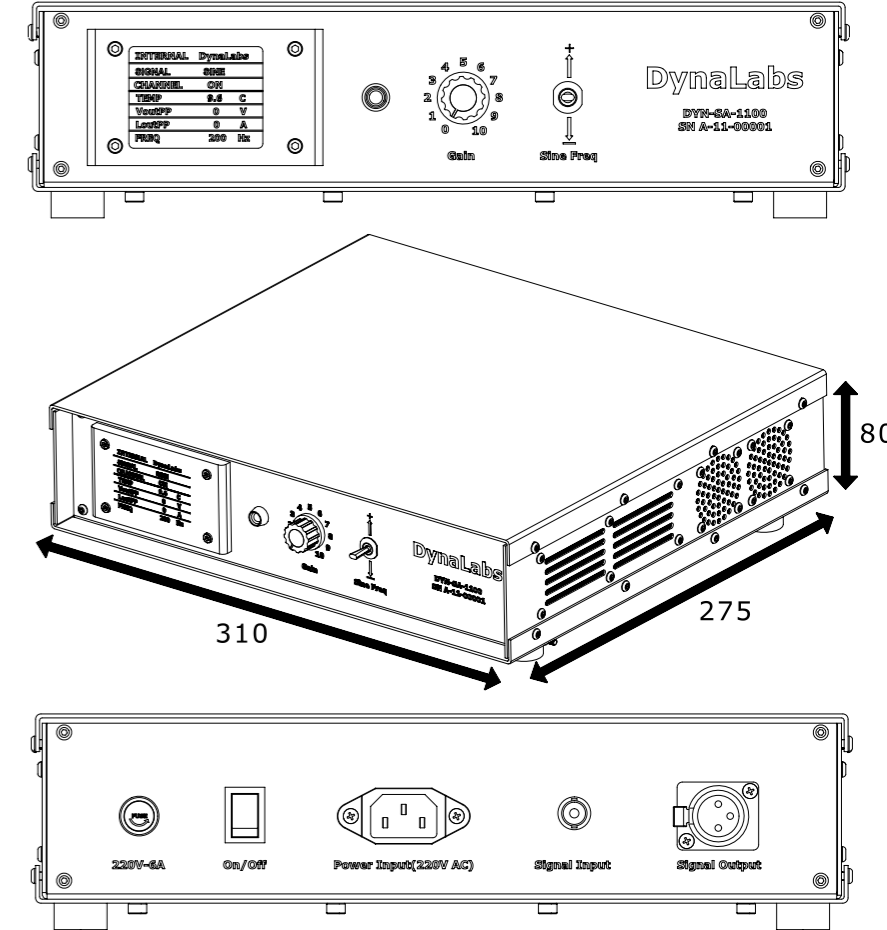

DYN-BLW-511 Monofaze Blower



System Components:Electrodynamic Shaker+DYN-SA-1100 Amplifier+Power Adapter(For Amplifier))+Shaker Power Cable(3PIN-3PIN)(5 meter)+Signal Cable(BNC-BNC)(5 meter)+Stinger Set+Pneumatic Union(R 1/2)+Hose Connection Adapter+Blower with 5 meter Hose+Fuse+User Manual

All dimensions in mm

All rights reserved. Reproduction or issue to third parties in any form whatsoever is not permitted without written authority from the proprietors. This document is subject to change without notice, and should not be construed as a commitment or representation by Dynalabs Ltd.

