

MODAL SHAKER

DYN-MS-100

DynaLabs

Modal shakers are used in modal testing to excite a structure under test to measure dynamic characteristics. It is designed specifically for modal analysis and helps identify the modal parameters of the structure, such as natural frequency, damping, and mode shape.



ALL-IN-ONE SHAKER

Both modal shakers and impulse hammers can be used in modal testing to excite the structures, but modal shakers have some advantages against impulse hammers such as cleaner and more accurate measurement data, the ability to test inaccessible points, and the capability to distinguish highly coupled modes. Modal shaker testing is also preferred for less noisy and more accurate results in many industrial applications.

DynaLabs modal shakers such as 20N and 100N have required amplifier inside the shaker body so it is extremely easy to use and handy. Also with the help of the integrated signal generator, it is very easy to try the test setups of perform easy tasks.



Advantages

- Lightweight, durable, portable and easy to use
- Modal stinger can be easily adjusted by the through-hole armature
- Adjustable trunnion base provides high flexibility
- Up to 25mm stroke and broad frequency range



Application Areas

- Modal analysis of structures
- Civil engineering
- Aircraft and constructions
- Aerospace testing
- Automotive testing
- Research and development



DYNALABS MUHENDISLIK LTD STI

Ostim OSB Mah. 100 Yil Bulvarı Ostim
No:55B/11 Yenimahalle 06374 Ankara
TURKEY

Phone: +90 312 386 21 89

Mail: dynalabs@dynalabs.com.tr

Web: www.dynalabs.com.tr

DynaLabs MODAL SHAKER

DYN-MS-100

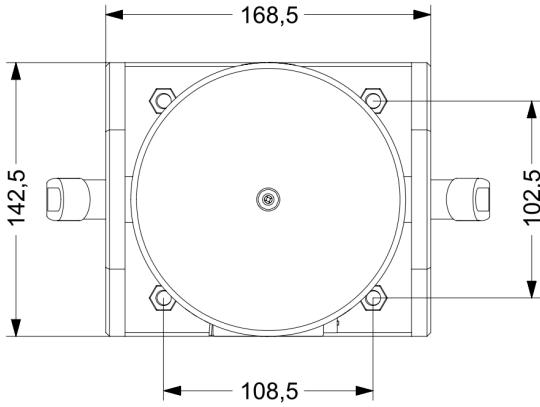

Stinger Set

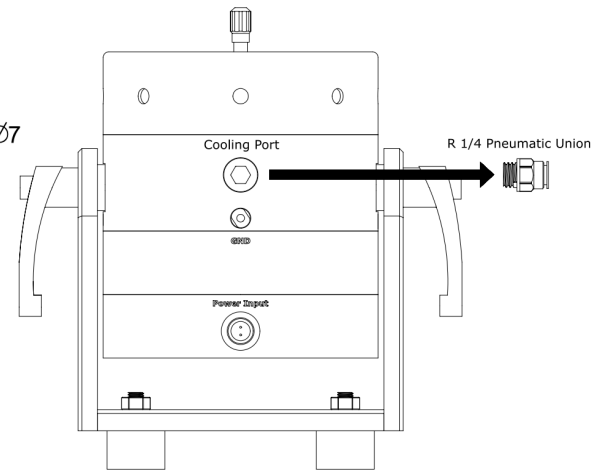
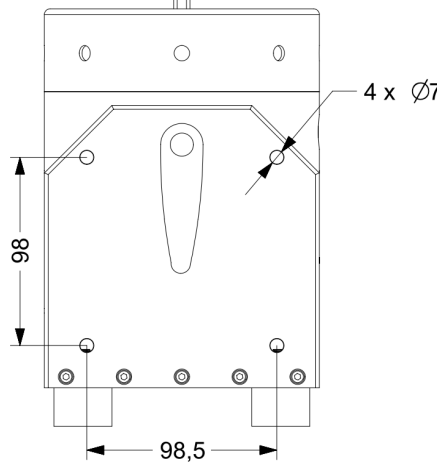
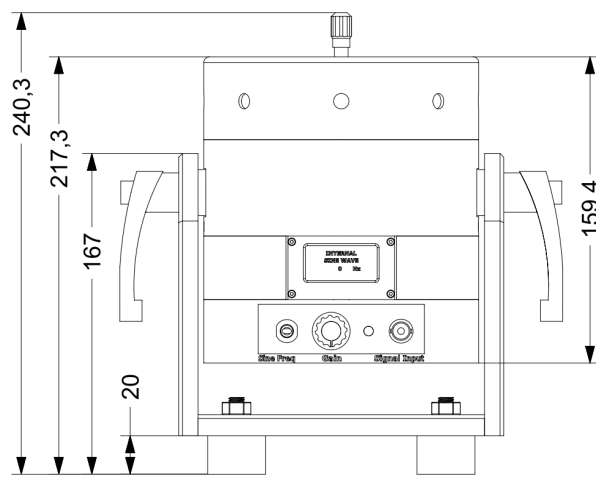
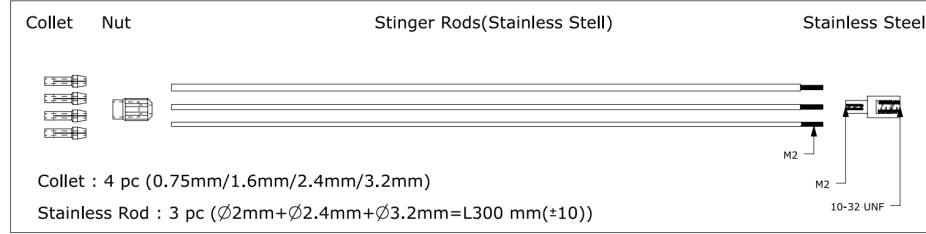

Output Force (Sinus)	Frequency Range	Displacement (P-P)	Maximum Acceleration	Shaker Weight	Cooling System	Max Velocity
100 N	0-7.5 kHz	10 mm	60 g	7.3 kg	Natural Convection	1 m/s
Operating Temp. Range	Suspension	Maximum Input Current	AMPLIFIER	External Signal Voltage Level	Power Supply Voltage	Power Supply Current
5-35 °C	Carbon Fiber	6A (RMS)	INTERNAL	1 VAC(PEAK)	24 V (DC)	5 A



DYNALABS MUHENDISLIK LTD STI

Ostim OSB Mah. 100 Yil Bulvarı Ostim
No:55B/11 Yenimahalle 06374 Ankara
TURKEY

Phone: +90 312 386 21 89

Mail: dynalabs@dynalabs.com.tr

Web: www.dynalabs.com.tr